

STEM CRUSHING – AN ECO-FRIENDLY WAY TO EFFECT ON FLAX DEW-RETTING

STIEBRIŅU SMALCINĀŠANA – EKOLOGISKI DRAUDZĪGA LINU APSTRĀDE

Zofija Jankauskienė, Algimantas Endriukaitis, Marius Balčiūnas

Upytė Research Station of the Lithuanian Institute of Agriculture
Linininkų 3, Upytė, Panevėžys district, 38 294, Lithuania
Ph: +(370)45555413, fax: +(370)45555573, e-mail: soja@upyte.lzi.lt

***Abstract.** Preparation of flax raw material – retted straw – is becoming more and more problematical since the straw is prepared by way of dew-retting, because this run under the open sky and fully couldn't be controlled, and this concludes in insufficient fibre quality. Besides of this, during the flax pulling process part of the stems is caught by the belts of the pulling combine LKV-4T and consequently is damaged (crushed). Thus fibre separation in this part of the stem usually runs more quickly and the quality of flax fibre along the stem becomes uneven. Top-part of the stem is damaged by thrashing apparatus. Furthermore, we should remember that the shape of flax stem is a cone, and dew-retting process at flax foot part takes much longer than at the top or at the strongly damaged middle part of the stem. The influence of crushing of fibre flax stems and desiccation was investigated at the Upytė Research Station of LIA in 2003. Special crushing apparatus was assembled on the flax combine LKV-4T. Desiccated with glyphosate and non-desiccated flax stems were crushed during pulling. The quality of fibre after stem crushing was higher.*

Keywords: dew-retting, crushing, fibre flax, fibre separation index, flax pulling combine, straw.

Introduction

During the flax pulling process part of the stems is caught by the belts of the pulling combine LKV-4T and consequently is damaged (crushed). Thus fibre separation in this part of the stem usually runs more quickly and the quality of flax fibre along the stem becomes uneven. Top-part of the stem is damaged by thrashing apparatus. Furthermore, we should remember that the shape of flax stem is a cone, and dew-retting process at flax foot part takes much longer than at the top or at the strongly damaged middle part of the stem.

The main producers of flax harvesting machines in Europe are Belgium, France, Russia and partly Czech Republic. Flax pulling machines produced in Belgium and France are fitted to the so called “western flax harvesting technology” when flax is pulled and spread on the ground in swaths for retting with capsules and the capsules are thrashed some time (about 1 week, depending on weather conditions) later in the same time returning the swath. Recent flax pullers produced in those countries have crushing tool for the root-end of the straw to accelerate ground-retting.

Currently over 90 % of flax pulling machines in Lithuania are of Russian origin. Flax is pulled by flax pulling combines when de-capsuling is carried out at the same time as flax pulling.

The Plant of Agricultural Enginery in Bezheck (Russia) had produced following types of flax pulling machines: LKV-4 T, LKV-4A, LK-4T, LK-4A, Rus' (Русь), Rusich (Русич), Rusich-M (Русич-М), KLP-1.5 [Chernikov, 1999]. The latest flax pulling combines have a crushing tool, however, such combines are still not available in Lithuania.

Russian researchers' experimental evidence suggests that a more homogenous dew-retting process along the stem, homogeneity of fibre colour could be achieved after crushing of the root-part of the straw [Boyarchenkova *et al.*, 1995; Bykov & Motorina, 1985; Kovaliov *et al.*, 2000; Kovaliov & Kozlov, 2002]. More intensive flax straw crushing trials in Russia were started in 1980, and several makes of crushing apparatus have been tested since then [Kovaliov & Kozlov, 1999; Kovaliov *et al.*, 2000, Kozlov, 2000; Kozlov, 2001; Kozlov.,

2001: Kovaliov & Kozlov, 2001]. The threshing of the foot-part of the stem (about 1/3) affords for better aeration (drying of the stem at first) and better development of the fungus taking part in the dew-retting process. In Russia the best results were achieved when green flax stems had been crushed at flax harvesting (the lowest force was required) [Kovaliov & Kozlov, 2002].

Summarizing the results of the investigations in Russia, carried out at The Flax Institute in Torzhok (ВНИИЛ) and Mechanization Institute in Tver' (ГНУ ВНИПТИМЛ), we can point out the following benefits of flax straw crushing:

- It shortens dew-retting by 3-10 days;
- Makes shuchability of the straw more even along the length;
- Increases straw quality;
- Increases fibre output by 1.1-2.5 %;
- Increases the quality of the fibre.

About 400 of Russian flax pulling combines available in our country have no crushing tool. Our aim was to try to assemble a crushing tool on the flax pulling combine LKV-4T and to investigate possible benefits of this tool on fibre parameters and on shortening of dew-retting. The main parameters of the crushing apparatus are presented in Table 1, the scheme in the Figure 1.

Table 1.

Main parameters of the crushing apparatus AP-1A	
Crushing force	3-4 kN
The frequency of rollers rotation	2,7 s ⁻¹
The required power	0,50 kW
Dimensions: mm	
Length	1100 mm
Width	370 mm
Height	650 mm
The mass	150 kg
Serving time-span	Not less than 7 years

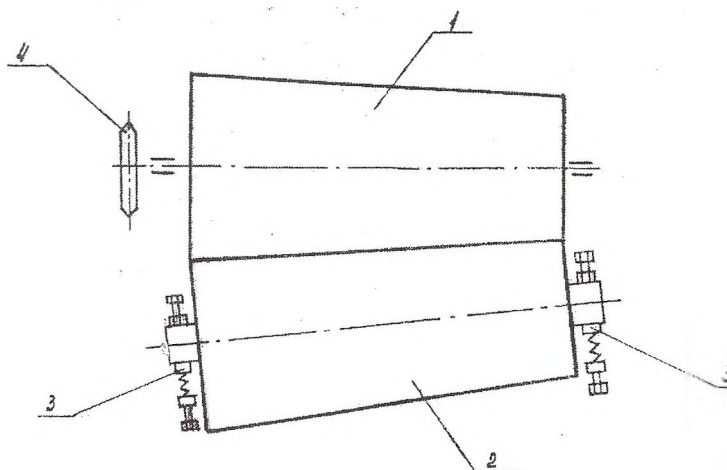

Fig. 1. The scheme of flax stem crushing apparatus AP-1A: 1 – upper leading roller; 2 – bottom squeezing roller; 3 - squeezing device; 4 - gear

Some authors point out to the desiccation of the straw in the field before harvesting as to the mean accelerating dew-retting process [Easson & Long, 1992; Kozlowski, 1992; Mukhin, 1992] thus some of our treatments were also focused on this.

Materials and methods

The trial was conducted on a Eutri-Endohypogleyic Cambisol [Buivydaite *et al.*, 2001]. The content of P₂O₅ in the soil plough layer was 160 mg kg⁻¹, content of K₂O – 193 mg kg⁻¹ (determined in A-L extraction), pH_{KCl} level – 7.0 (potentiometrically), humus content – 1.74 % (by Thyurin method). In the field rotation flax followed winter wheat. Each treatment had a flax plot of 30 m² replicated four times. Randomised plot design was used.

Flax cv. Hermes was sown at the beginning of May by a sowing machine SL-16 at a seed rate of 22 million viable seed per hectare at 10 cm row spacing. Insecticide Fastac 10 EC (alfacipermetrine 100 g l⁻¹) 100 ml ha⁻¹ was applied at seedling stage, herbicide Glean® 75 DF (chlorsulphurone 750 g kg⁻¹) 7 g ha⁻¹+ Kemiwett™ S (ethohilate alcohol) 0.1 % - when flax was 6-10 cm in height.

Before harvesting flax samples from 1 m² (0.25 m² from 4 randomly chosen places in each plot) for the evaluation of biological yield were prepared.

Flax was harvested at an early-yellow ripening stage in the treatments 1-3 (on the 13th of August) and 2 weeks later in the treatments 4 and 5 (waiting until desiccation shows an effect) (see trial design). Flax stem crushing was done in treatments 3 and 5.

Trial design:

1. Check (Flax was pulled by hand);
2. Flax pulling by combine LKV-4A, without crushing;
3. Flax pulling by combine LKV-4A, with crushing;
4. Desiccation*, flax pulling by combine LKV-4A, without crushing;
5. Desiccation*, flax pulling by combine LKV-4A, with crushing.

*Desiccation was done by spraying on flax stand Glyphosate 1.08 kg ha⁻¹ (Roundup Classic 3 l ha⁻¹) with 300 l ha⁻¹ of water.

Flax swath was returned several times by DEHONDT returner.

The weather conditions were suitable for flax dew-retting for three weeks after harvesting, but during this period dew-retting process was not completed. Since the beginning of September the weather became dry, and the dew-retting process continued throughout September (Table 2).

Table 2.

Mean weather temperature, precipitation and air humidity during flax vegetation and dew-retting periods (Uptytė, 2003)

May				June			
Date, ten-day period	Rainfall, mm	T _{av} , °C	Air humidity, %	Date, ten-day period	Rainfall, mm	T _{av} , °C	Air humidity, %
I	10.2	12.1	-	I	4.0	16.8	-
II	22.4	12.5	-	II	13.9	13.6	-
III	6.0	16.2	-	III	25.8	15.2	-
Per month	38.6	13.6	-	Per month	43.7	15.3	-
July				August			
Date, ten-day period	Rainfall, mm	T _{av} , °C	Air humidity, %	Date, ten-day period	Rainfall, mm	T _{av} , °C	Air humidity, %
I	21.9	17.8	-	I	5.0	19.2	69.4
II	28.0	19.7	-	II	20.7	17.1	77.7
III	25.8	22.8	-	III	53.7	14.4	88.5
Per month	75.7	20.1	-	Per month	79.4	16.9	78.5

September				October			
Date, ten-day period	Rainfall, mm	T _{av} , °C	Air humidity, %	Date, ten-day period	Rainfall, mm	T _{av} , °C	Air humidity, %
I	15.8	11.5	86.7	I	40.6	8.5	93.9
II	0	13.7	82.9	II	10.9	4.3	91.8
III	19.9	11.9	84.1	III	-	-	-
Per month	35.7	12.4	84.6	Per month	-	-	-

When flax straw became grey (because of dew-retting process) fibre separation analyses were started by a tool OOV [Patarimai lininkui, 1975]. Since 9th of September (27 days under dew-retting conditions in the field) to 14th of October a weekly sample of 100 dew-retted straws was tested in 4 replications from each treatment. Fibre separation was measured in three places of the flax stem (top, middle and foot) cutting out 10 cm length segments.

Also dew-retted flax straw was broken up by machine tool SMT-200, fibre was hackled using combs number 9 and 13. Number of long fibre was determined organoleptically in the laboratory, flexibility – by a device G-2, the strength – by a device DK-60.

The data were analysed by ANOVA, and means of LSD at P=0.05 are presented [Tarakanovas, 1999].

Results and discussion

Crop density was not sufficient (1201-1306 plants. m⁻²) because of the great surge of flea-beetles at flax germination period. This also had influence on flax yield: it was 3.4-4.4 t ha⁻¹ of un-retted straw and 0.65-0.84 t ha⁻¹ of seed.

Dew-retting period. Already 12 days after the beginning of dew-retting process the upper side of flax straw swath in the treatments 1-3 changed the colour and in 18 days (since the middle of September) all swath became greyish, thus the evaluation of fibre separation index was started. Desiccated straw (treatments 4 and 5) stayed yellow, un-retted for a long time. When organoleptically evaluating schuched fibre weekly, even after 27 days of dew-retting fibre was grey in the treatments 1-3, but still had impurities. After crushing the fibre was cleaner (treatment 3) when compared with that in treatments 1 or 2. Fibre in treatments 4 and 5 was grey-yellowish, contained impurities. The same tendency was noticed on all testing dates – 9th, 16th, 23rd of September. On 30th of September the fibre in the treatments 4 and 5 became greyer when compared to the previous samples and even more greyer on 7th and 14th of October but still had yellow-brown shade and impurities. Visually fibre was cleaner after crushing (treatments 3 and 5).

Fibre separation index. According to the experience of Russian scientists, flax straw is fully dew-retted when fibre separation index is within the range of 4.0-7.0. But in our trials after schutching the fibre contained impurities even at this level of fibre separation index, thus we continued retting trial until the meteorological conditions allowed to do this. Generally, it is very difficult to decide when the dew-retting is completed, because after scutching fibre was not very homogenous. Also it is noteworthy that the straw in the treatments 4 and 5 was retted by 2 weeks shorter.

As the data in Table 3 show, fibre separation index was the highest in the middle of the stem where the belt had damaged flax stem during the pulling. In the treatment 1 where flax was pulled by hand, dew-retting ran more gradually along the stem, e.g. fibre separation index was more similar between the top, middle or foot part of the straw.

When analysing data sampled on 9th of September, 27 days after starting of dew-retting, fibre separation index (FSI) in the treatments 1, 2 and 3 was over 4.0. Fibre separation index after

flax pulling by a combine was significantly higher than after pulling by hand. FSI in the treatments after flax desiccation (4 and 5) (but dew-retted only 14 days) was close to 4.

A similar situation was on 16th of September, 34 days from the beginning of dew-retting for treatments 1, 2 and 3 and 21 days for treatments 4 and 5. Fibre separation index after stem crushing was a little higher than that after pulling without crushing and significantly higher than after pulling by hand.

On 23rd of September no significant differences of FSI between treatments 1, 2 and 3 were found. IFS in the treatments after desiccation was significantly lower compared with that in the check (after pulling by hand). IFS was a little higher in the treatments after crushing (compared treatments 3 to 2 and 5 to 4), but the differences were insignificant.

On the 30th of September IFS differences between treatments were insignificant.

In a weekly period (from 30th of Sept. to 7th of Oct.) average fibre separation index increased sharply (rainy weather) and was close to that in the check. IFS was insignificantly higher after crushing compared to that of un-crushed straw.

Table 3.

The dynamics of fibre separation index at the different places of the stem (Upytė, 2003)

Treatment	Place	Sampling date					
		9 th Sep	16 th Sep	23 rd Sep	30 th Sep	7 th Oct	14 th Oct
1. Check (Flax was pulled by hand)	Top	4.4	4.4	5.6	6.0	6.7	6.4
	Middle	6.4	6.0	8.1	7.6	7.6	7.9
	Foot	6.4	6.3	7.2	7.8	7.1	6.7
	aver.	5.7	5.6	6.9	7.1	7.2	7.0
2. Flax pulling by combine LKV-4A, without crushing	Top	5.2	6.2	4.0	6.1	6.4	6.6
	Middle	7.5	7.7	7.7	8.4	8.4	8.4
	Foot	6.9	6.8	7.1	8.1	8.0	8.1
	aver.	6.6	6.9	6.3	7.5	7.6	7.7
3. Flax pulling by combine LKV-4A, with crushing	Top	5.2	6.8	6.0	6.7	7.7	8.1
	Middle	7.0	8.0	7.8	7.7	8.7	9.0
	Foot	7.0	7.1	7.5	7.5	7.8	8.3
	aver.	6.4	7.3	7.1	7.3	8.1	8.5
4. Desiccation, flax pulling by combine LKV- 4A, without crushing	Top	3.4	3.9	3.5	4.2	4.8	5.2
	Middle	4.7	4.6	6.2	6.6	7.4	7.7
	Foot	4.0	4.2	4.2	5.0	6.8	7.6
	aver.	4.0	4.2	4.6	5.2	6.3	6.8
5. Desiccation, flax pulling by combine LKV- 4A, with crushing	Top	2.4	2.6	3.8	3.7	5.6	5.1
	Middle	4.4	4.0	5.4	5.1	7.1	7.3
	Foot	4.5	4.4	5.1	5.4	7.5	7.4
	aver.	3.8	3.7	4.8	4.7	6.7	6.6
LSD ₀₅	Top	1.14	1.37	2.00	1.42	1.60	1.48
	Middle	0.89	0.90	1.71	1.36	0.57	0.99
	Foot	0.61	1.35	1.62	0.85	1.54	1.06
	aver.	0.66	1.02	1.46	0.92	0.94	0.70

On 14th of October the straw in the treatment 3 seemed to be over-retted – IFS was 21 % higher than that after pulling by hand and by 10 % higher than after pulling without crushing.

Average fibre separation index data are presented in Figure 2.

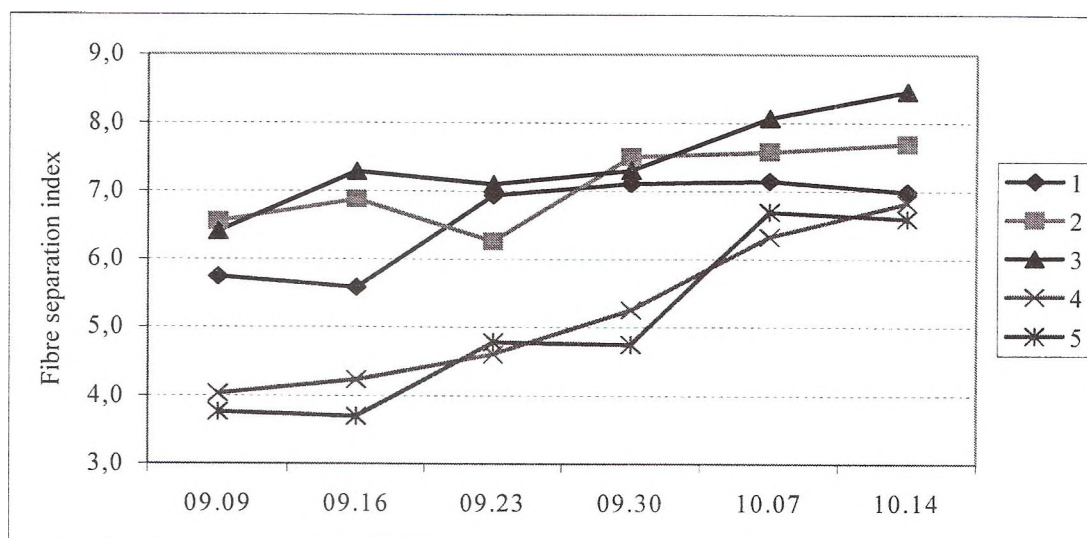

Fig. 2. The dynamics of the average fibre separation index

1. Check (Flax was pulled by hand); 2. Flax pulling by combine LKV-4A, without crushing; 3. Flax pulling by combine LKV-4A, with crushing; 4. Desiccation, flax pulling by combine LKV-4A, without crushing; 5. Desiccation, flax pulling by combine LKV-4A, with crushing.

The dynamics of long fibre number (Table 4). Long fibre number in the treatments 4 and 5 was significantly lower till the 30th of September (fibre had impurities). Later the differences disappeared. The same tendency of higher number after straw crushing could be noticed.

The correlation between number value and fibre separation index (FSI) was calculated and reliable (99 %, Fisher's test) relation was found. The determination coefficient R^2 was 0.61 for the linear type of correlation ($Y = -4.92225 + 1.05374X$).

The highest determination coefficient ($R^2 = 0.78$) among the other types of correlation had Quadratic regression type ($Y = -84.098 + 16.532X - 0.749X^2$).

Table 4.

The dynamics of long fibre number (Upytė, 2003)

Treatment	Sampling date					
	9 th Sep.	16 th Sep.	23 rd Sep.	30 th Sep.	7 th Oct.	14 th Oct.
1. Check (Flax was pulled by hand)	11.5	11.5	11.0	11.3	10.5	10.8
2. Flax pulling by combine LKV-4A, without crushing	11.5	11.0	11.5	11.4	11.0	11.1
3. Flax pulling by combine LKV-4A, with crushing	11.9	11.3	12.0	11.8	10.9	11.1
4. Desiccation, flax pulling by combine LKV-4A, without crush.	9.3	9.0	9.3	9.1	10.9	10.5
5. Desiccation, flax pulling by combine LKV-4A, with crushing	9.0	9.0	9.1	9.4	10.8	10.5
LSD ₀₅	0.42	0.49	0.77	0.60	1.04	0.57

The dynamics of long fibre tenacity (Table 5). Fibre tenacity in the treatments 4 and 5 was significantly higher till 16th of September (fibre was not well-retted). The strongest fibre was obtained from the samples on 23rd of September. Later fibre tenacity tended to decrease, but

in the treatments 2 and 3 it was going more sharply (over-retting). Significant differences in fibre tenacity between crushed and not crushed straw were not observed.

Table 4.

The dynamics of long fibre tenacity (kg F) (Upytė, 2003)

Treatment	Sampling date					
	9 th Sep.	16 th Sep.	23 rd Sep.	30 th Sep.	7 th Oct.	14 th Oct.
1. Check (Flax was pulled by hand)	12.2	11.1	14.6	11.7	9.8	6.1
2. Flax pulling by combine LKV-4A, without crushing	12.9	11.0	12.8	9.8	7.9	6.0
3. Flax pulling by combine LKV-4A, with crushing	12.4	11.2	13.8	9.9	7.7	6.1
4. Desiccation, flax pulling by combine LKV-4A, without crush.	16.2	13.8	13.9	13.5	10.5	8.6
5. Desiccation, flax pulling by combine LKV-4A, with crushing	15.9	14.2	14.8	14.1	10.5	8.0
LSD ₀₅	2.37	1.68	2.69	1.78	1.98	1.00

The correlation between fibre tenacity and fibre separation index (FSI) was calculated and reliable (99 %, Fisher's test) relation was found. 62.26 % of all cases were under the linear type of correlation-regression ($Y = 10.48289 - 0.36656X$). Paired regression type Modified Power ($Y = 12.60627 \cdot 0.93903^X$) showed the highest determination coefficient ($R^2 = 0.76$).

Conclusions

1. In the treatment where flax was pulled by hand dew-retting ran more gradually along the stem, e.g. fibre separation index was more similar between the top, middle or foot part of the straw
2. After crushing flax fibre at the foot-part of the straw was cleaner (had less impurities) and was more homogenous.
3. The significant correlation between long fibre number and fibre separation index as well as between fibre tenacity and fibre separation index was found.

Bibliography

1. Buivydaite, V.V., Vaicys, M., Juodis, J., Motuza A. Lietuvos dirvožemių klasifikacija. Vilnius: Lietuvos mokslas, 2001. P. 76.
2. Boyarchenkova, M.M., Kovaliov, M.M., Smirnov, V.I., Ivanov, A.D. Effektivnost pliuschenija steblej l'na v komlevoj chasti pri tereblenii. *L'nianoje delo*, № 4, 1995. S.18-22.
3. Bykov, N.N., Motorina, R.I. Effektyvnost pliuschenija komlej. *Lion i konoplia*, № 4, 1985. S.38-39.
4. Chernikov, V.G. Mashiny dlia uborki l'na (konstrukcija, teorija, rasčiot): Monografija Moskva: INFRA, 1999. S.135.
5. Easson, D.L, Long, E.N.J. Pre-harvest Retting of Flax with Glyphosate. In Sharma, H.S.S., Van Sumere C.F. (eds.). *The biology and Processing of Flax*. Belfast: M Publications, 1992. P. 251-259.
6. Kovaliov, M.M., Kozlov, V.P. Rasčiot rezhima rabotypliuschitel'nogo aparata l'nokombainov. *Agrarnaja nauka*, № 5, 1999. S. 15-17.
7. Kovaliov, M.M., Smirnov, V.I., Kozlov, V.P. Texnologija i texniceskije sredstva pliuschenija steblej l'na. *Nauchno-texniceskij progress v inzhinernoj sfere APK Rossii (Materialy nauchno-praktičeskoj konferencii, 6-7 oktiabtia 1999 g.)*. Moskva: GOSNITI, 2000. S.125-128.
8. Kovaliov, M.M., Kozlov, V.P. Racionalnyje parametry i forma valcov pliuschitel'nogo aparata l'nouboroshnyx mashin. *Traktory i sel'skoxozijstvennyje mashiny*, № 11, 2001. S. 23-26.
9. Kovaliov, M.M., Kozlov, V.P. *Pliushchilnyje aparaty l'nouborochnyx mashin (konstrukcija, teorija, rachiot)*: Monografija, Tver, 2002. S. 13, 22, 61, 62.

10. Kovaliov, M.M., Smirnov, V.I, Kozlov, V.P., Boyarchenkova, M.M. Sovershenstvovaniye texnologii i texnicheskikh sredstv dlia pliushcheniya stieblej l'na. *Len – na poroge XXI veka (Materialy nauchno-prakticheskoy konferencii, 1-3 marta 2000 g.)*. Vologda, 2000. S. 213-215.
11. Kozlov, V.P. Pliushchilnyj aparat l'nokombainov: rabochij process valcov. *Traktory i selskoxoziajstvennyje mashiny*, № 9, 2000. S. 35-37.
12. Kozlov, V.P. Parametry valcov pliushchilnych aparatov l'nokombainov. *Agrarnaja nauka*, № 10, 2001. S. 17-19.
13. Kozlov, V.P. Transpotirovaniye steblej valcovymi pliushchilnymi aparatami l'nouborochnyx mashin. *Agrarnaja nauka*, № 3, 2001. S. 127-129.
14. Kozlowski, R. Retting of Flax in Poland. *In Sharma, H.S.S., Van Sumere C.F. (eds.), The biology and Processing of Flax*, Belfast: M Publications, 1992. P. 251-259.
15. Mukhin, V.V. Harvesting and Retting of Flax in the Soviet Union. *In Sharma, H.S.S., Van Sumere C.F. (eds.), The biology and Processing of Flax*, Belfast: M Publications, 1992. P. 229-250.
16. Patarimai linininkui (Sudarytojas A. Andrišiūnas). Vilnius, 1975. P. 120.
17. Tarakanovas, P. Statistinių duomenų apdorojimo programų paketas "Selekcija". Akademija: Lietuvos žemdirbystės insititutas, 1999. P. 6-16.